

GWENT POLICE ABNORMAL LOADS PROCEDURE



1.0 Introduction

This Procedure provides a framework for the management and operation of Gwent Police's response to escorting Abnormal Indivisible Loads (AILs) to meet the requirement of legislation and regulations governing the movement of AILs.

Gwent Police recognises the importance to the nation's economy of the ability of the haulage industry to safely, successfully and efficiently transport AILs on the highway network.

Legislation does not contain any requirement for any abnormal load to be escorted. Legally enforceable standards exist for the notification of abnormal load movement to both the Chief Constable and the Highway Authorities.

Gwent Police are not responsible for ensuring the safe operational passage of abnormal loads on the roads of Gwent, this is the role of the haulier. However, officers should still be aware of their Common Law duty in relation to public safety.

PRINTED VERSIONS SHOULD NOT BE RELIED UPON. THE MOST UP TO DATE VERSION CAN BE FOUND ON THE INTRANET POLICIES SITE

FLOW CHART FOR ABNORMAL LOAD PROCEDURE

NOTIFICATION RECEIVED FROM HAULIER WHICH WILL BE CLASSIFIED AS NEEDING EITHER A SELF ESCORT, PRIVATE ESCORT OR POLICE ESCORT

ABNORMAL LOADS OFFICER CHECKS TO ENSURE THE PROPOSED ROUTE IS SUITABLE AND IF REQUIRED PRESCRIBES ALTERNATIVE ROUTE

DETAILS FROM NOTIFICATION FORM PLACED ON THE ABNORMAL LOADS SECTION OF THE FORCE COMPUTER SYSTEM (ORIS) AND GIVEN A UNIQUE REFERENCE NUMBER (URN)

PRIOR TO ENTERING GWENT POLICE AREA DRIVERS ARE REQUIRED TO CONTACT FORCE CONTROL ROOM AND QUOTE UNIQUE REFERENCE NUMBER. FCR CREATE AN ORIS LOG TO INCORPORATE THE ABNORMAL LOADS URN AND UPDATE THE STATUS OF THE ABNORMAL LOAD WITHIN THE FORCE AREA. IN THE EVENT THAT A CHANGE OF ROUTE IS REQUIRED URGENTLY, THIS WILL BE RESOLVED BY TELEPHONE RESOLUTION AND ORIS UPDATED

THE ORIS INCIDENT LOG SHOULD BE CLOSED WHEN NOTIFICATION IS RECEIVED FROM THE DRIVER THAT THE VEHICLE HAS LEFT THE FORCE AREA. THE ABNORMAL LOADS OFFICER FILES THE NOTIFICATION ALPHABETICALLY. THE NOTIFICATIONS ARE ARCHIVED AND REMOVED AFTER THREE MONTHS. IN THE CASE OF POLICE ESCORTED LOADS DOCUMENTATION THIS IS RETAINED FOR 12 MONTHS

THIS FLOW CHART OUTLINES BRIEF PROCEDURAL DETAILS FOR ABNORMAL LOADS AND SHOULD BE READ IN CONJUNCTION WITH THE ROLE OF THE ABNORMAL LOADS OFFICER SECTION 1.2.4 FOR A MORE COMPREHENSIVE EXPLANATION

1.1 Risk Assessments and Health and Safety Considerations

The Gwent Police Service Dynamic Assessment should be applied as necessary. A training package in the use of risk assessment will be provided to all police personnel if required and requested.

1.2 Specific Instructions,

1.2.1 Legislation

The Motor Vehicles (Authorisation of Special Type) (General) Order 2003 permits the use of vehicles and/or loads, which cannot comply with the maximum permitted weight, either gross or axle weight, for the class of vehicle being used for transporting a load. It also contains the regulations for loads, which exceed the maximum width permitted by Construction and Use Regulations, agricultural vehicles and many other miscellaneous vehicles. The Order can be accessed via the Police National Legal Database or by contacting the Abnormal Loads Officer who holds a written copy.

The legislation is in the most part permissive, in that, providing the haulier complies with the requirements of notification procedures, an abnormal load can be moved without the need for any permit or authorisation. The only exceptions are as follows:

Loads exceeding 5 metres and up to 6.1 metres wide, which require a VR1 (see section 3.3 of this procedure re definition of VR1) from the Highway's Agency, which authorises the movement, but not the route, day or date.

Once the VR1 has been issued the haulier can then use the normal notification procedure, quoting the VR1 reference.

Loads exceeding 6.1m wide, 30m rigid length or 150,000 kilograms in weight require a Special Order from the Secretary of State (this role has now been taken over by the Highways Agency - Electronic Service Delivery Abnormal Loads - ESDAL) A Special Order ensures that the route is negotiable and may lay down certain conditions. It does not, however, replace the notification procedure.

Legislation does not contain any requirement for any abnormal load to be escorted. However whilst this is accepted Gwent Police still have a duty of care to ensure the safety of the travelling public on the roads of this Force area. There are requirements for attendants for various categories of abnormal loads (Road Vehicles (Authorisation of Special Types) (General) Order 2003 provides these requirements)

The legislation does permit the attendant to an agricultural vehicle to be in an accompanying vehicle and there is provision in the Roads Vehicles (Lighting) Regulations for amber beacons to be used in this practice, but this is the only reference to any form of escort.

1.2.2 PROPOSALS FOR THE SELF OR PRIVATE ESCORTING OF ABNORMAL LOADS.

The escorting of AILs by Gwent Police on roads within the Gwent Police Area is no longer a function that can be sustained and the self or private escorting of the majority of AILs will be permitted as from the 1st March 2004.

Gwent Police reserves the right to charge for the escort of Exceptional Abnormal Loads, if these loads which because of their route or extreme dimensions would be more safely escorted by a Police escort.

Such Loads will be identified by the Abnormal Loads Officer, and subject to mutual agreement the opportunity to pay for a Police escort at Police Special Duty Rates will be offered to the Haulier.

The Haulier must always be given the opportunity to provide their own self or private escort, as the Abnormal Loads Officer can only recommend that a Police Escort is used.

1.2.3 ESCORTING PROCEDURE

Gwent Police does not provide an accreditation service for Self or Private Escorting operators.

Abnormal Loads will require a Self or Private Escort when they exceed,

- **M4/M48 MOTORWAY**

- 4.3m (14'1") in width
 - 30.5m (100') overall length or
 - 100 tonnes in weight

- **DUAL CARRIAGEWAYS**

- 4.1m (13'4") in width
 - 30.5m (100') overall length or
 - 100 tonnes in weight

- **ALL OTHER ROADS**

Dimensions will be set following an assessment of the proposed route by the Force Abnormal Loads Officer. This is documented by the Abnormal Loads Officer and is faxed to the Haulier. A copy is kept for three months following the movement of the AIL. The Command and Control System is also updated (+LU) in respect of the unique record for that AIL and records are available from the ORIS archive (Command and Control).

The civilian escort will be provided for the purposes of giving warning to the driver of that vehicle or combination, and to any other person, of any danger likely to be caused by the presence on the road of that vehicle or combination.

The civilian self/private escort(s) are expected to comply with any instructions issued by Gwent Police, and to abide with the principles of the Highways Agency Code of Conduct in relation to escorting abnormal loads. If the Haulier fails to comply with Police guidance or the provisions of the HA Code of Conduct, no specific offences are committed. However, any outcomes that occur due to Haulier negligence will be examined in respect of Road Traffic Legislation (e.g. causing obstruction/driving without reasonable consideration for other road users etc.)

A Haulier who cannot supply such escort, and/or requests the provision of a police escort will be required to give at least two clear days notice of any proposed movement. In calculating the clear days notice required, Bank Holidays, Christmas Day, Good Friday and any Saturday or Sunday do not count.

A charge for the time of Police Officers and each Police vehicle used may be made.

Headquarters (Finance Department) will provide the rates in line with guidance set out in ACPO guidance for charging of police services "Paying The Bill 2"

Cancellation or change of movement dates within two clear days of the originally notified date, may require payment to be made in full for the hours the officer(s) were originally required to be on duty. This decision will be taken in consultation with Senior Officers from Uniform Operations Department.

For occasional movements, when this localised service is required, police assistance may still be given without payment. This would only be in circumstances where the operation does not require any physical escorting, but simply traffic control, and could be carried out by Police Officers, Traffic Wardens or authorised Police Community Safety Officers. If an escort is required, the Abnormal Loads Officer, (or FCR Operator - outside normal office hours) will refer the matter to the Inspector or in his/her absence the Sergeant, Roads Policing Unit for consideration.

The permitting of self/private escorting of abnormal loads will not remove the requirement to comply with the Road Traffic Act or any associated legislation regarding the use of any motor vehicle on a road. Gwent Police Roads Policing Unit will be pro-active in the enforcement of the legislation and conduct of self/private escorts subject to the exigencies of other duties.

Individual Roles and Responsibilities

1.2.4 ABNORMAL LOADS OFFICER

The AIL Officer will still be required to administer Abnormal Load Notifications in accordance with the Construction and Use and Special Type General Order legislation (see definitions section). The introduction of Self/Private Escorts will have minimal effects on the actual administration procedures undertaken by the department.

Notifications from hauliers are received by either fax, e-mail or ESDAL (Electronic Service Delivery Abnormal Loads) within the Abnormal Loads Office, this is situated at Headquarters.

Details of each notification are received by the Abnormal Loads Officer, the loads requiring either a self escort or Police escort, are recorded on ORIS Command and Control System and are retained for 3 months (on ORIS) after the date of the AIL movement (to allow the gathering of statistics). Hard copy files are retained for 3 months (as a back-up) or in the case of Police arranged escorts – 12 months)

Route, day and time of travel and dimensions are checked and verified for accuracy and suitability by the Abnormal Loads Officer.

If the route is unsuitable or affected by roadwork schemes or other features, an alternative route is identified, in consultation with other forces and/or Highway Agencies if necessary.

A decision is made to establish if the load requires escorting. A reply is sent to the haulier, by the Abnormal Loads Officer, containing any instructions for re-routing and/or escorts.

If a haulier requests a Police Escort or if the load is exceptional and requires specific resources, the Roads Policing Unit Inspector is advised, by the Abnormal Loads Officer, for arrangements to be made for the required staff and cost recovery from the haulier. Cost recovery is achieved by the Abnormal Loads Officer in collaboration with Finance Department. Decisions are recorded on the AIL record and on ORIS under (+LU) against the unique reference for that AIL.

Although much of the responsibility for the safety of the movements of AILs will be placed on the driver and escorts, there is still a duty of care on the Abnormal Loads Officer to ensure that the Haulier is advised of the safest, most suitable route. This is documented on the AIL record which is faxed to the Haulier and put on ORIS under (+LU) against the unique reference for that AIL. The responsibility for the safe movement of the AIL always remains with the Haulier.

Routes that have restricted access due to street furniture etc have previously been acceptable, as the police officers escorting would use their powers of traffic regulation to negotiate the obstructions. The withdrawal of police from these duties will require the Abnormal Loads Officer to re-examine these routes in collaboration with the relevant Highway Authority, either at Unitary Authority or Welsh

Government level and the Roads Policing Unit. This will be achieved through existing lines of communication. Where any risk is identified, consultation will be undertaken between all parties to seek a solution.

There are some AIL routes, that whilst perfectly suitable for self/private escorts for the majority of the route, have a particular obstruction or location which would require the attendance of police resources to negotiate the feature safely. Allocation of police resources to such instances will be decided by negotiation between the Abnormal Loads Officer and the Inspector, Roads Policing Unit. Any allocation of police resources will be appended to ORIS (+LU) and to the live incident when created.

Where there is any future adoption of an accreditation scheme (Police Reform Act 2002), allowing appropriately qualified persons (not police officers) to regulate or control traffic in relation to the escorting of AILs, the requirement for/involvement of Police Officers in such instances will be reviewed in conjunction with this procedure.

1.2.5 CONTROL ROOM STAFF

The following process will be adhered to;

- Where information is received, either from the escort or driver, or from a neighbouring force of an abnormal load to be self/privately escorted within the Gwent Police Area.
- Obtain the unique reference number or full details of the haulier, load and journey details. Check these details against those recorded on the load record, under the ORIS plus code 'LE' (Load Enquiry) record.
- Check that there are no adverse conditions or traffic problems on the route, and advise the escort/driver accordingly. Any advice given will be added to the live incident log.
- Abnormal loads cannot be re-routed without the consent of the Abnormal Loads Officer, and in some cases the Highway Authorities. If the Abnormal Loads Officer is unavailable advice regarding re-routing is to be obtained from the Roads Policing Unit duty Sergeant.
- Care should also be taken in offering advice to the Haulier regarding the parking of the load in respect of the safety of the location. Any risk assessment is the responsibility of the Haulier, as is the safe parking of the load and compliance with any Road Traffic Legislation or local Regulation. Any advice given will be added to the live incident log.
- If the AIL is one that requires a police escort (under the provisions of this procedure), advise the Abnormal Load Officer or Roads Policing Unit duty Sergeant in their absence, by radio or telephone, of the AIL dimensions and the route. The Sergeant will allocate the previously arranged resources as required.

- If the load is travelling into another police area, it is the responsibility of the escort/driver to contact that force direct. FCR Operator will remind the driver/escort of this fact.
- Upon the completion of the incident enter the required closing code (+CAB).
- If any problems are encountered, FCR Operators will defer the incident log for the attention of the Abnormal Loads Officer who will enquire into the circumstances. Any action required will be considered by the members of staff responsible for monitoring this procedure.

1.2.6 ADMINISTRATION

Notifications of AIL movements are received by the Abnormal Loads Officer, by fax, e-mail or letter. These documents are filed (hard copy) as a reference.

The Abnormal Load Officer creates an AIL record on the ORIS Command and Control System (+LU) and provides a unique reference number (urn) to the Haulier by fax.

The driver of the AIL is provided with the ORIS log URN and will contact Gwent Police Force Control Room before entering the Gwent Police Area.

The FCR Operator taking the call from the AIL driver retrieves the AIL record from ORIS by use of the URN.

An incident Log is then created (with the AIL record attached) and, where appropriate, the Roads Policing Unit duty Sergeant is contacted (see above).

2.0 The Legal Basis and Legitimate Aims

- Road Vehicles (Construction & Use) Regulations 1986
- Road Vehicles (Authorisation of Special Types) (General) Order 2003 (S.T.G.O.)

3.0 Human Rights Certification of Compliance

The procedure has been checked for compliance with the Human Rights Act; with particular reference to the legal basis of its precepts: the legitimacy of its aims; the justification and proportionality of the actions intended by it; that it is the least intrusive and damaging option necessary to achieve the aims; and that it defines the need to document the relevant decision making process's and outcomes of actions.

4.0 Compliance with The Welsh Language Scheme

This procedure aims to comply with the organisations Welsh language Scheme in terms of dealing with the Welsh speaking public, impact upon the public image of the organisation and the implementation of the language scheme.

5.0 Risk Assessment and health and safety Considerations

The Gwent Police Service Dynamic Assessment should be applied as necessary. A training package in the use of risk assessment will be provided to all police personnel if requested or required.

6.0 Procedure Identification Section

Procedure Title: ABNORMAL LOADS

Reference: 301/6 b issue 4

ACPO Lead: ACC

Service Area Owner: Uniform Operations

Department Responsible: Uniform Operations

Links to other Policies/Procedure: Data Protection, Information Security, PNC, Direction and Control Complaints, Emergency Vehicle Offences Detected by Automatic Cameras, Event Planning, Health and Safety, Police Vehicle Accidents, Road Traffic Collisions, Vehicle Recovery.

Procedure Implementation Date: 1st March 2004 reviewed and amended OPG 5th June 2007 reviewed 13th October 2009 Feb 15th 2012

Procedure Review Date: Feb 2014

Appendix 'A'

Consultation

CODE OF PRACTICE

Self-Escorting of Abnormal Loads and Abnormal Vehicles

This document has been prepared in accordance with the criteria of the Cabinet Office. A copy of the criteria is available on request from the Highways Agency, C6, 5 Broadway, Broad Street, Birmingham B15 1BL or is available on the Cabinet Office website at <http://www.cabinetoffice.gov.uk/regulation/consultation/code.htm>

TABLE OF CONTENTS

Notifications of ALL movements are received by the Abnormal Load Officer, by fax, e-mail or letter. These documents are filed (hard copy) as a reference.8

Introduction	13
Self Certification	14
Vehicle Requirements	15
Vehicle Specification	15
Size and Type	15
Colour	15
Exterior Lights	15
Markings and Identification	16
Equipment and Information to be Carried in Escort Vehicle	19
Road Side Safety Equipment	19
Emergency Safety Equipment	19
Job Specific Reference Information.....	19
Communications Equipment	19
Escort Person Specification	21
Level 1 - Escort Person	21
Main Duties and Responsibilities	22
Essential Skills and Qualifications	22
Desirable Skills and Qualifications.....	22
Personal Protective Equipment.....	22
Level 2 - Accredited Escort Person	23
Additional Main Duties and Responsibilities	23
Essential Skills and Qualifications	23
Route to Level 2 Accreditation	23
Operation	24
General Requirements	24
Escorting Criteria	25
Special Order Loads.....	25
Appendix 1	26
Appendix 2	27

Introduction

This Code of Practice is voluntary and does not prescribe hard and fast rules, but provides practical guidelines, which may be departed from in appropriate circumstances. It is not intended to be a comprehensive statement of the law's requirements.

This said, it is an authoritative statement of best practice, which has been agreed to by the organisations listed in **Appendix 2**. It not only points out many of the legal obligations which need to be met, but also contains information and explanations which are designed to ensure that those escorting abnormal loads¹ and abnormal vehicles on the highways do so in a manner which maximises safety. It has also been notified in draft to the European Commission in accordance with Directive 98/34/EC, as amended by Directive 98/48/EC.

Self-escorting offers greater flexibility for scheduling moves and therefore should enable the loads to travel at off peak times when there is less traffic. This will both reduce traffic disruption to other road users and improve journey times for the haulier. It will also reduce the burden on the Police, who currently undertake this role, thereby allowing them to pursue other important activities.

Legislation² requires hauliers to notify the movement of most abnormal loads and abnormal vehicles to the police before moving them by road. There is also a requirement to notify heavier loads and vehicles to highway authorities to ensure that bridge structures can accommodate these heavy loads. In Scotland, the term highway authority shall be deemed to be road authority. For the largest and heaviest abnormal loads, prior permission before moving is required from the Highways Agency. If it is an abnormal vehicle, authorisation is required from the Department for Transport.

Hauliers involved in the movement of abnormal loads or abnormal vehicles have a responsibility to ensure that each movement is conducted in a controlled and safe manner. This shall equally apply if the load or vehicle is being self-escorted. Some larger and heavier loads are required to have an attendant. In these cases where the self-escort person is not travelling in the vehicle carrying either the abnormal load, or in the abnormal vehicle, the self-escort person may fulfil both roles provided that the requirements of an attendant are met.

The term self-escorting applies to either a haulier or a private company engaged by a haulier escorting an abnormal load or an abnormal vehicle. In this Code, two levels of escort person have been distinguished and will be referred to as Level 1 and Level 2. A Level 1 person has no powers to stop or direct other road users and is simply to warn other road users. A Level 2 person has powers to stop and direct other road users in England and Wales by being an "*accredited person*" authorised by a Police

¹ Abnormal Indivisible Load as defined in Schedule 1, paragraph 2 by The Road Vehicles (Authorisation of Special Types) (General) Order 2003 (SI 1998) and Indivisible Load as defined by Regulation 3(2) of The Road Vehicles (Construction & Use) Regulations 1986 (SI 1078)-namely a load that cannot without undue expense or risk or damage be divided into two or more loads for the purpose of being carried on a road

² Schedule 12 of The Road Vehicles (Construction & Use Regulations) 1986 as amended (SI 1986/1078). Schedule 5 of The Road Vehicles (Authorisation of Special Types) (General) Order 2003 (SI 1998).

Chief Constable³. Details on how to obtain Level 2 accreditation are yet to be formalised. The accredited person status authorised by a Police Chief Constable does not apply to Scotland and any accreditation issued in England and/or Wales in terms of the Police Reform Act 2002 will not be applicable in Scotland.

This Code of Practice, which applies throughout England, Wales and Scotland, is intended to provide a nation-wide standard that is recognised by both industry and the police authorities alike. The Accredited Level 2 escort person is not applicable in Scotland. The standardised vehicle specification applies for both Level 1 and Level 2 escort personnel. Having a standard livery helps the general public and in particular other road users to recognise these vehicles, thereby alerting them to the movement of an abnormal load or abnormal vehicle so they can exercise greater caution, as appropriate.

The Code of Practice covers:

- the requirements for an escort vehicle – including details of its appearance, markings, warning beacons, and equipment to be carried;
- the person specification for a self-escort person – a description of the roles, responsibilities and duties; and
- general operating practices – thresholds for self-escorting, documentation to be carried and practices to be adopted whilst actively engaged in self-escorting.

Self Certification

The haulier shall ensure that their self-escort vehicles comply with this Code of Practice and that their personnel have sufficient training and/or expertise to carry out self-escorting duties competently and safely in a manner which accords with the requirements of Road Traffic and Health and Safety Legislation.

If the escorting is subcontracted by the haulier, the subcontractor shall ensure that their self-escort vehicles comply with this Code of Practice and their personnel shall have sufficient training and/or expertise to carry out self-escorting duties competently and safely, in a manner which accords with the requirements of Road Traffic and Health and Safety Legislation.

When Special Order loads are to be escorted and self-escort vehicles are used, these vehicles shall conform to this Code of Practice.

When notifying the movement of an abnormal load or abnormal load vehicle to the Police, the Police may ask for a self-certificate (a self-escorting declaration is appended to this document as Appendix 1) or other evidence to show that the vehicles and personnel to be used comply with this Code of Practice.

³That is, a person designated by a Chief Officer of Police under Schedule 5 and Section 41 of the Police Reform Act 2002.

Vehicle Requirements

The primary role of any escort vehicle is to alert other road users and pedestrians of the presence of an abnormal load or abnormal vehicle. The escort person in the vehicle shall also act as the contact point with others while escorting the load or vehicle.

The escort vehicle and its occupants shall assist the abnormal load or abnormal vehicle in safely negotiating the transport route, as well as controlling and directing traffic when accredited Level 2 persons are employed.

Vehicle Specification

Size and Type

An escort motor vehicle shall have a minimum of four wheels. The escort vehicle must afford the driver good visibility. To facilitate good visibility to the rear and side, the vehicle shall be fitted with exterior mirrors on both sides. The escort vehicle shall not form any part of the units carrying or hauling the abnormal load or the abnormal vehicle.

Colour

To be conspicuous to other road users and pedestrians the escort vehicle shall be of a uniform colour being white, yellow, orange or silver.

Exterior Lights

In addition to the normal vehicle lighting requirements, the escort vehicle shall also be fitted with additional warning lights and beacons as follows:

Flashing amber warning Beacons⁵ shall be fitted to the roof of the escort vehicle to warn other road users and pedestrians to the presence of an abnormal load or abnormal vehicle. These shall be full roof width 'bar' type, fitted transversely and visible to the front and rear of the vehicle. No more than two banks of lights are permitted. These may be demountable. Warning Beacons shall be approved and conform to Economic Commission for Europe (ECE) Regulation 65⁶.

The amber warning beacons shall only be used whilst the vehicle is actively engaged in escorting an abnormal load or abnormal vehicle. The operation of these lights on an escort vehicle travelling at more than 25 mph is currently prohibited, therefore, the vehicle operator will need to apply to the Department for Transport⁷ (with details of those vehicles requiring exemption) for an individual vehicle exemption from the Lighting Regulations.

⁵ Beacon defined as visible around 360°

⁶ ECE Regulation 65 – Special Warning Lamps

⁷ Vehicle Standards and Engineering (VSE) 4, fax: 0207 944 2069

Markings and Identification

The front of the vehicle shall be marked clearly to identify that it is an escort vehicle. This shall be done by marking “Escort vehicle” or “Escort” in solid black lower case or first letter upper case, remaining lower case lettering in forward script on the front of the vehicle. The marking will be in plain sans serif font (e.g. Helvetica or Arial), and the lettering shall be of a minimum of 150 mm high and a width to height ratio approaching one. Shadowing, italics and other lettering effects are not permitted. No other text or logos shall be located near to this lettering.

There shall be a roof sign displaying “abnormal load” in lower case lettering using a sans serif font (e.g. Helvetica or Arial) and with a width to height ratio approaching one, which should be clearly visible from both the front and rear. This sign shall be lit when escorting. The sign shall not be illuminated at any other time. Lighting regulations⁸ only permit red lighting to face the rear of the vehicle and any colour other than red to face forward. This should be taken into consideration in the design of any sign (suggested red internal lighting to rear and white to front). This sign may be demountable.

To help alert other road users approaching the escort vehicle from the front, during the day the vehicle shall use dipped beam headlamps when escorting the abnormal load or abnormal vehicle.

To help alert other road users approaching the escort vehicle from the rear, high visibility markings shall be applied to the rear of the vehicle. These will be chevron markings of alternate red retro-reflective material and yellow vinyl non retro-reflective material (or equivalent), each with a strip width of 250mm on vans and above, and 150mm for cars and car-derived vans.

The chevron markings shall be at 60° to the horizontal plane, with the chevrons pointing upwards and matching colours meeting at the vertical centre line of the vehicle. As much of the rear of the vehicle as possible should be marked in this way and any vehicle fittings should be cut around, e.g. light assemblies, number plates etc.

In addition to the chevron markings on the rear of the vehicle, outline markings consisting of 25mm - 50mm wide red retro-reflective prismatic grade material shall be fitted along the roof edge and to the outside door pillars in the case of the van and outside edge of the rear window in the case of a car.

When the rear doors of a self-escort van are opened a 25mm – 50mm wide red retro-reflective prismatic grade strip of material shall be fitted along the rear facing edge of the doors, along the open roof edge and along the floor sill. In the case of a self-escort car the 25mm – 50mm wide red retro-reflective prismatic grade strip of material shall be fitted to the rear facing edge of the boot lid or tailgate.

⁸The Road Vehicle Lighting Regulations 1989 as Amended

If a piece of equipment is fitted or attached to the rear of the escort vehicle and obscures the chevron markings (e.g. a crash cushion in the upright position), the chevron markings shall be replicated on the equipment, so that the pattern continues to be visible.

To maintain high vehicle visibility from different angles, the red and yellow chevron markings shall be continued in an unbroken pattern onto the side of the vehicle body for a distance of 300mm measured from the rear most corner of the vehicle body. The markings shall be over the full height of the vehicle body.

To alert other road users approaching the vehicle from the side, a single continuous strip 200mm wide of yellow retro-reflective tape shall be fitted at or below the horizontal centreline of the vehicle from the extended chevron marking to at least the front wheel arch.

The name of the vehicle operator and/or owner may be displayed upon the side of the vehicle forward of the extended chevron markings, not too close to the side chevron markings or the single retro-reflective strip. No company livery shall be displayed on the front or rear of the vehicle.

Figure 1 – Illustration of an escort vehicle (not to scale)

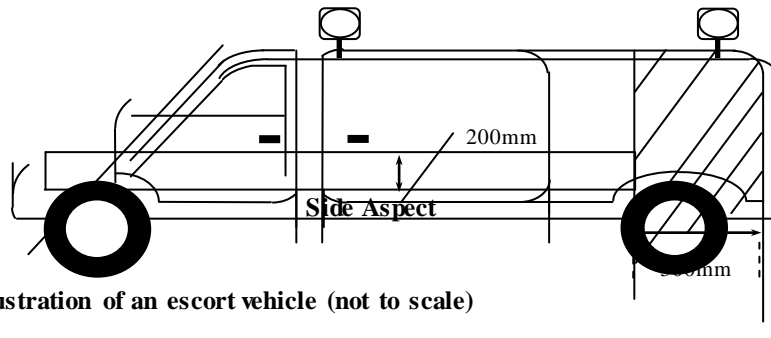
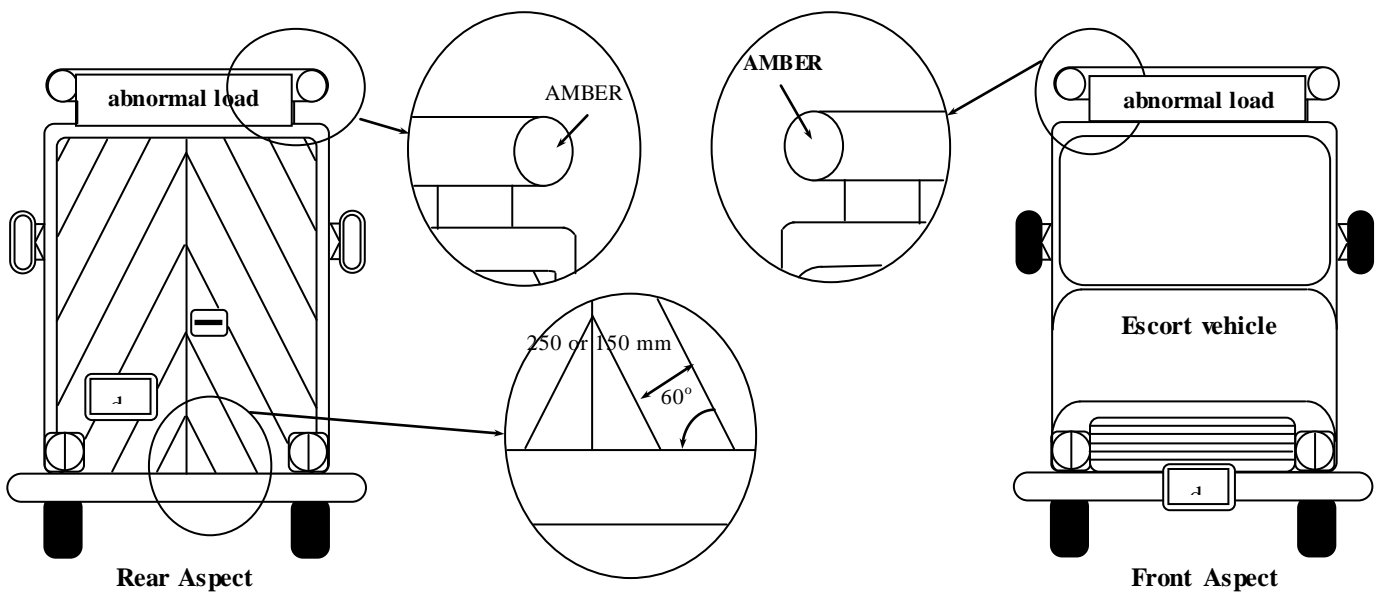

Figure 2 – Illustration of an escort vehicle (not to scale)



Equipment and Information to be Carried in Escort Vehicle

Road Side Safety Equipment

To effectively manage road side safety during planned or unplanned stops, each escort vehicle shall be equipped with the following:

- A minimum of 12 weighted traffic cones to BS 873⁹, minimum 450mm (18") tall with Des 2 retro-reflective sleeve or an EC or EEA standard which in practice provides standards to those standards contained in a British Standard; and
- A minimum of 4 lighting units compatible for installation upon traffic cones above to BS 3143¹⁰ an EC or EEA standard which in practice provides standards to those standards contained in a British Standard.

Emergency Safety Equipment

In the event of an incident during the journey, it is expected that the escort vehicle will be the first to the scene. Therefore each vehicle shall be equipped with, (and ideally personnel trained in the use of):

- a powder or CO₂ Fire Extinguisher Kite marked and British Approval for Fire Equipment (BAFE) approved to BS EN3¹¹ or an EC or EEA standard which in practice provides standards to those standards contained in a British Standard; and
- a '1 to 10' employee CE approved¹² First Aid Kit.

The fire extinguisher shall have a valid certificate¹³, and the First Aid Kit maintained and the contents within their 'use-by-date'.

Job Specific Reference Information

An escort vehicle shall carry the following information:

- a copy of the route approval, consents and restrictions as appropriate;
- appropriate maps;
- contact telephone numbers for Police/Highway Authority Control rooms; and
- up to date traffic and road work information if applicable.

Communications Equipment

An escort vehicle shall have a:

- communications link to the abnormal load or abnormal vehicle; and
- communications link to the Police/Highway Authority Control Rooms (and emergency services if required).

⁹ British Standard 873 – Specification for Traffic Cones and Cylinders

¹⁰ British Standard 3143 – Specification for Road Danger Lamps

¹¹ British Standard EN3 – Portable Fire Extinguishers

¹² CE Approved means compliance with European Standards

¹³ British Standard 5306 – Maintenance of Portable Fire Extinguishers and British Standard 6643 – Recharging Fire Extinguishers apply

A direct radio voice link shall be installed in the escort vehicle to enable communications between the escort vehicles and the abnormal load or abnormal vehicle¹⁴. Either a short-range (under 3km) two-way radio system¹⁵ shall be used or a long-range (3–8km) radio system accompanied by the appropriate radio licence. The use of hand-held microphones for 2-way radio equipment when driving is not prohibited by the new regulations dealing with the use of hand-held mobile phones or similar devices when driving. However there is still a risk of distraction when using a microphone (whether hand-held or hands-free). Consequently, drivers continue to risk prosecution under existing powers dealing with the requirement to have proper control of a vehicle.

Hand-held mobile phones or similar devices shall not be used by the escort person whilst driving¹⁶. A mobile phone or other device is defined as 'hand-held' if it is, or must be, held at some point during the course of making or receiving a call (or text, or email, or other data – e.g. to/from a GPS navigation device). 'Driving' will include pausing at traffic lights or in temporary traffic jams. Hands free equipment is not prohibited. If installed, then the system should be to BS Guide DD 235¹⁷. Note however the warning about the risk of distraction and prosecution in paragraph 3.26, which applies equally to hand-free mobile phones.

¹⁴ This type of equipment can be used while driving.

¹⁵ Short range radio systems are readily available and can be used without the need for a registered frequency licence

¹⁶ The Road Vehicles (Construction and Use) (Amendment)(No 4) Regulations 2003 SI 2695.

¹⁷ British Standard Guide DD 235 – Guide to In-Vehide Information Systems

Escort Person Specification

It is the responsibility of hauliers to satisfy themselves that their own escort personnel are sufficiently competent to undertake the task of escorting abnormal loads or abnormal vehicles. Competent means that they are suitably trained or experienced for the role. Where a subcontractor is employed the subcontractor shall ensure that their staff are competent, through training and/or experience for the role.

There are two levels of escort person:

- Level 1 – an escort person who has no powers to stop and direct other road users; and
- Level 2 – an accredited escort person who has the authority to stop and direct other road users.

Level 1 - Escort Person Main Duties and Responsibilities

The main duties and responsibilities of an escort person are:

- to escort the abnormal load or abnormal vehicle along the approved transport route acting as a warning to other road users and pedestrians;
- to ensure that any special instructions/restrictions either for the escort vehicle or the vehicle carrying the abnormal load are adhered to;
- to act as a point of contact and to manage the interface between the abnormal load convoy and Police/Highways Authority control rooms, bridge authorities and emergency services if required;
- to alert the emergency services as appropriate in the event of an incident involving the abnormal load or abnormal vehicle; (If suitably trained use the First Aid Kit and Fire Extinguisher as appropriate).
- to place traffic cones and warning beacons around the abnormal load or abnormal vehicle when it is stationary for a period of time in order to warn other road users; and
- to ensure that the escort vehicle is 'fit for purpose' and conforms to this Code of Practice.

Essential Skills and Qualifications

Essential Skills and Qualifications required are:

- a minimum age of 21 years old;
- a full standard driving licence held; and
- to be competent through training and/or experience in the movement and transportation of abnormal loads or abnormal vehicles.

Desirable Skills and Qualifications

Desirable Skills and Qualifications are:

- a basic First Aid Training and Qualification¹⁸; and
- basic use of a Fire Extinguisher Training¹⁹.

Personal Protective Equipment

Each escort person actively involved in escorting an abnormal load or abnormal vehicle shall be equipped with a long sleeve high visibility fluorescent yellow jacket conforming to BS EN 471²⁰. This shall be worn at all times when the escort person is outside of the escort vehicle²¹.

¹⁸ For example – St John’s Ambulance 1 day certified course – ‘Lifesaver First Aid’, or equivalent

¹⁹ For example – Typical Fire Service ½ day Basic Fire Awareness and Hands on Training Course, or equivalent

²⁰ British Standard BS EN 471 – Specification for High Visibility Warning Clothing

²¹ Those undertaking self escorting operations should also consider the use and/or availability of other personal protective equipment considered as necessary

Level 2 - Accredited Escort Person

An accredited escort person has the authority to stop and direct other road users. A Level 2 escort person shall have all the requirements of a Level 1 escort person plus the following.

Additional Main Duties and Responsibilities

To enable the safe passage of the abnormal load or abnormal vehicle along the approved transport route by stopping and or directing traffic as appropriate, minimising inconvenience and danger to other road users and pedestrians in the process.

Essential Skills and Qualifications

Accreditation from a Police Chief Constable to undertake the traffic direction of other road users.²²

Route to Level 2 Accreditation

The route to achieve accreditation has yet to be fully defined. This Code of Practice will be updated when this information is available.

²² Police Reform Act 2002, section 38, and paragraph 12 of Schedule 4 refer

Operation

This section covers the general requirements and operating practices that shall be conformed to when actively engaged in self-escorting an abnormal load or abnormal vehicle. It also gives general guidance on the minimum threshold when self-escorting shall be used.

Some abnormal loads or abnormal vehicles need an attendant. (Attendant is defined in the relevant legislation).²³ An escort person can also carry out this role provided they are not travelling in the vehicle carrying the abnormal load or abnormal vehicle and providing they fully meet the legislative requirements referred to.

General Requirements

The Police Abnormal Loads Officer and haulier shall agree on a case-by-case basis the minimum number of escort vehicles and escort personnel required for the movement.

Escort persons shall check and satisfy themselves that there are no adverse traffic or weather conditions on the agreed transport route prior to the start of the move, or leg of move.

Escort operators shall make contact with each Police authority traffic control room 30 minutes prior to reaching a suitable safe stopping place, before entering another Police Force area, or before departure within a force area, and upon leaving the boundary.

The vehicle carrying the abnormal load or the abnormal vehicle shall not divert from the agreed route unless directed to do so by Police and only then when the appropriate highway and or bridge authorities approval has been obtained.

Drivers of the vehicle carrying the abnormal load, or abnormal vehicle shall not contravene road traffic rules.

On Motorways and Dual Carriageways an escort vehicle should be positioned to the rear of the abnormal load, at a distance to give adequate warning to other road users of the abnormal load.

On two-way roads and at traffic islands or intersections an escort vehicle shall be positioned to the front of the abnormal load to give adequate warning to other road users of the abnormal load.

Those engaged in the movement of abnormal loads or abnormal vehicles shall keep the build up of traffic behind them to a minimum and shall, where practicable, be prepared to stop at suitable locations to relieve traffic congestion.

In case of a vehicle break down, escort personnel shall deploy roadside safety equipment to 'cone off' the abnormal load or abnormal vehicle when it is safe to do so and notify the Police / Highway Authority Control Room of the breakdown.

Where self-escort vehicles are changed along the route the appropriate paperwork and information shall be handed over.

²³ The Road Vehicles (Construction & Use Regulations) 1986 (SI 1078) , Schedule 12 paragraph 2. The Road Vehicles (Authorisation of Special Types) (General) Order 2003 (SI 1998), Schedule 6.

Escorting Criteria

General guidance

As general guidance the following dimensions may be applied to decide if the movement of an abnormal load requires an escort. Generally an escort vehicle is required if:

Measurement	For motorways	For all other roads
Load / vehicle width exceeds	4.6m	4.1m
Overall vehicle length exceeds	-	30.5m
Vehicle gross weight exceeds	130 tonnes	100 tonnes

The above measures are for guidance and may differ between individual police forces only as the final decision rests with the Police, normally the Police Abnormal Load Officer. Individual Police authorities may wish to vary these requirements, along with timing of the move on specific stretches of road.

Depending on the situation or location the Police may also require Police escorts for all or part of the route. These will be notified to the haulier when an application is made to the local Police Abnormal Load Officer for a route approval.

A haulier is able to choose to self-escort an abnormal load or abnormal vehicle below these guidelines.

Special Order Loads

Certain Special Order movements due to the extreme nature of the load or complexity of the transport route may require police escorts for all or part of the journey. A combination of self-escort and police escort vehicles may be used, to be agreed by both parties.

Upon notifying the police, each police authority will advise the haulier if a police escort is required and whether self-escorts can assist the movement.

Self-escorting declaration

I the undersigned certify that:

- the following self / escort vehicles, meet the Vehicle Specification contained within the Self-Escorting of Abnormal Loads and Abnormal Vehicles Code of Practice; and
- the driver(s) of the self / escort vehicle(s) meet the Essential Criteria contained within the Self-Escorting of Abnormal Loads and Abnormal Vehicles Code of Practice.

Registration number	Vehicle Type

Signature	Name in block capitals	Status in Company	Name of Company

This document is endorsed by the following organisations:

Association of Chief Police Officers
Association of Chief Police Officers Scotland
Freight Transport Association
Heavy Haulage Association
Road Transport Association